

Chapter 2

Induction Motor and Faults

Abstract The chapter deals with general description of an induction motor followed by different faults. First, construction of induction motor has been discussed. Then a review of induction motor fault has been presented. Faults like rotor broken bar, mass unbalance, stator faults, single phasing, crawling, bearing faults, etc. are discussed along with causes and effects.

Keywords Bearing fault · Broken rotor bar · Construction · Crawling · Induction motor · Mass unbalance · Single phasing · Stator fault

Chapter Outcome

After completion of the chapter, readers will be able to gather knowledge and information regarding the following areas:

- Construction of induction motor
- Different classes of induction motor
- Different motor faults
- Statistics on motor fault
- Broken rotor bar
- Rotor mass unbalance
- Stator winding fault
- Single phasing
- Crawling
- Bearing fault
- Over/under voltage, overload.

2.1 Introduction

An induction motor comprises a magnetic circuit interlinking two electric circuits which are placed on the two main parts of the machine: (i) the stationary part called the stator and (ii) the rotating part called the rotor. Power is transferred from one

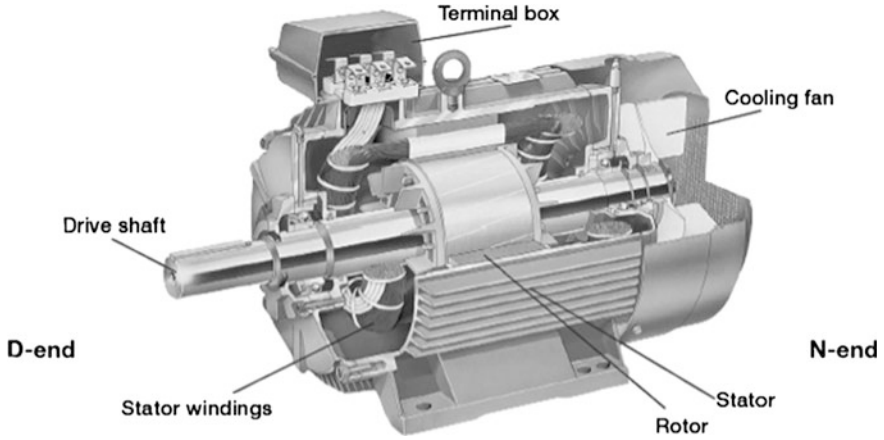

Fig. 2.1 An induction motor (dissected)

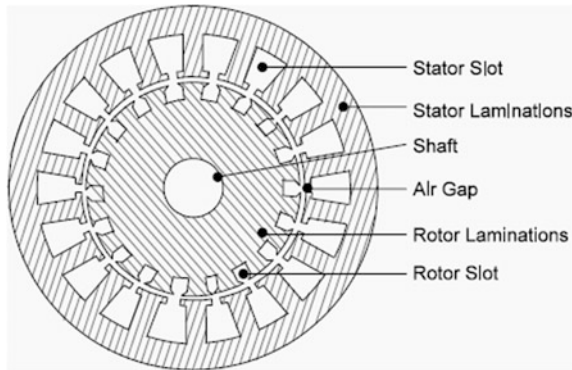

Fig. 2.2 Magnetic circuit of stator and rotor of an induction motor

part to the other by electromagnetic induction. For this induction machine is referred as an electromechanical energy conversion device which converts electrical energy into mechanical energy [1]. Rotor is supported on bearings at each end. Generally, both the stator and rotor consist of two circuits: (a) an electric circuit to carry current and normally made of insulated copper or insulated aluminum and (b) a magnetic circuit, shown in Fig. 2.2, to carry the magnetic flux made of laminated magnetic material normally steel (Fig. 2.1).

2.2 Construction

(a) Stator

The stator, shown in Fig. 2.3, is the outer stationary part of the motor. It consists of (i) the outer cylindrical frame, (ii) the magnetic path, and (iii) a set of insulated electrical windings.

- (i) **The outer cylindrical frame:** It is made either of cast iron or cast aluminum alloy or welded fabricated sheet steel. This includes normally feet for foot mounting of the motor or a flange for any other types of mounting of the motor.
- (ii) **The magnetic path:** It comprises a set of slotted high-grade alloy steel laminations supported into the outer cylindrical stator frame. The magnetic path is laminated to reduce eddy current losses and heating.
- (iii) **A set of insulated electrical windings:** For a 3-phase motor, the stator circuit has three sets of coils, one for each phase, which is separated by 120° and is excited by a three-phase supply. These coils are placed inside the slots of the laminated magnetic path.

(b) Rotor

It is the rotating part of the motor. It is placed inside the stator bore and rotates coaxially with the stator. Like the stator, rotor is also made of a set of slotted thin sheets, called laminations, of electromagnetic substance (special core steel) pressed together in the form of a cylinder. Thin sheets are insulated from each other by means of paper, varnish [2]. Slots consist of the electrical circuit and the cylindrical electromagnetic substance acts as magnetic path. Rotor winding of an induction motor may be of two types: (a) squirrel-cage type and (b) wound type. Depending on the rotor winding induction motors are classified into two groups [1–3]: (i) squirrel-cage type induction motor and (ii) wound-rotor type induction motor.

- (i) **Squirrel-cage type induction motor:** Here rotor comprises a set of bars made of either copper or aluminum or alloy as rotor conductors which are embedded

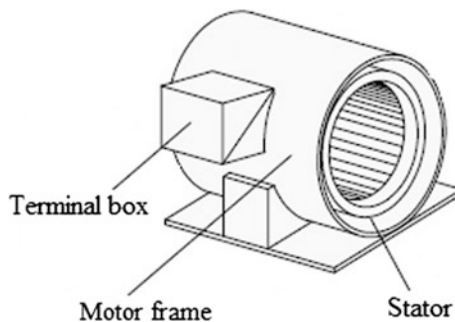

Fig. 2.3 Stator of an induction motor

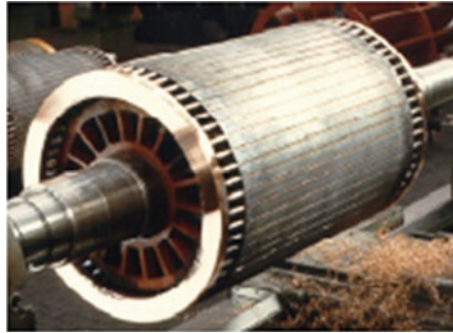

Fig. 2.4 Squirrel-cage rotor



Fig. 2.5 Slip ring rotor

in rotor slots. This gives a very rugged construction of the rotor. Rotor bars are connected on both ends to an end ring to make a close path. Figure 2.4 shows a squirrel-cage type rotor.

- (ii) **Wound-rotor type induction motor:** In this case rotor conductors are insulated windings which are not shorted by end rings but the terminals of windings are brought out to connect them to three numbers of insulated slip rings which are mounted on the shaft, as shown in Fig. 2.5. External electrical connections to the rotor are made through brushes placed on the slip rings. For the presence of these slip rings this type of motor is also called slip ring induction motor.

Besides the above two main parts, an induction motor consists some other parts which are named as follows:

- (i) **End flanges:** There are two end flanges which are used to support the two bearings on both the ends of the motor.
- (ii) **Bearings:** There are two set of bearings which are placed at both the ends of the rotor and are used to support the rotating shaft.
- (iii) **Shaft:** It is made of steel and is used to transmit generated torque to the load.

- (iv) **Cooling fan:** It is normally located at the opposite end of the load side, called non-driving end of the motor, for forced cooling of the both stator and rotor.
- (v) **Terminal box:** It is on top or either side of the outer cylindrical frame of stator to receive the external electrical connections.

2.3 Operation

When the stator winding of an induction motor is connected to a three-phase supply, a uniform rotating magnetic field is produced therein [3], which induces e.m.f. in the rotor which is free to rotate coaxially with the stator core with the help of ball bearings. Rotor being short circuited, either through the end rings or an external resistance, currents are produced due to this induced e.m.f. This current interacts with the rotating magnetic field to develop a torque on the rotor in the direction of the rotating magnetic field. As the rotor is free to rotate, the torque will cause it to move round in the direction of the stator field. This makes a three-phase induction motor as self-starting.

In transforming this electrical energy into mechanical energy, in an induction motor some losses occur which are as follows:

- Friction and windage losses, 5–15 %
- Iron or core losses, 15–25 %
- Stator losses, 25–40 %
- Rotor losses, 15–25 %
- Stray load losses, 10–20 %.

Full-load motor efficiency varies from about 85 to 97 %.

Induction motors are simpler, cheaper, and efficient. Among them squirrel-cage induction motor is more rugged and work more efficiently compared to wound-rotor induction motor. If supply voltage and frequency are constant, then a squirrel-cage induction motor runs at a constant speed which makes it suitable for use in constant speed drive [1, 2]. Several standard designs of squirrel-cage induction motors are available in the market to fulfill the requirements of different starting and running conditions of various industrial applications. These are classified [4] as class A, class B, class C, and class D. In Table 2.1, a comparison of different classes of squirrel-cage induction motors is presented.

Table 2.1 Various classes of squirrel-cage induction motor

| | Class A | Class B | Class C | Class D |
|------------|--|---|---|--|
| Properties | Normal starting torque, high starting current and low operating slip | Normal starting torque, low starting current and low operating slip | High starting torque and low starting current | High starting torque, low starting current and high operating slip |
| Uses | Fan, pump load etc. where torque is low at start | For constant speed drive such as pump, blower | Compressor, conveyors, crushers etc. | For driving intermittent load, e.g. punch press etc. |

Table 2.2 Statistics on motor faults/failures [8]

| Type of faults | Number of faults/failures | | | | |
|----------------------|---------------------------|-------------------|-------------------|----------|------------------|
| | Induction motor | Synchronous motor | Wound-rotor motor | DC motor | All total motors |
| Bearing | 152 | 2 | 10 | 2 | 166 |
| Winding | 75 | 16 | 6 | – | 97 |
| Rotor | 8 | 1 | 4 | – | 13 |
| Shaft | 19 | – | – | – | 19 |
| Brushes or slip ring | – | 6 | 8 | 2 | 16 |
| External device | 10 | 7 | 1 | – | 18 |
| Others | 40 | 9 | – | 2 | 51 |

2.4 Faults: Causes and Effects

Induction motors are rugged, low cost, low maintenance, reasonably small sized, reasonably high efficient, and operating with an easily available power supply. They are reliable in operations but are subject to different types of undesirable faults. From the study of construction and operation of an induction motor, it reveals that the most vulnerable parts for fault in the induction motor are bearing, stator winding, rotor bar, and shaft. Besides due to non-uniformity of the air gap between stator-inner surface and rotor-outer surface motor, faults also occur. Different studies have been performed so far to study reliability of motors, their performance, and faults occurred [5, 6]. The statistical studies of IEEE and EPRI (Electric Power Research Institute) for motor faults are cited in [7, 8]. Part of these studies was to specify the percentage of different faults with respect to the total number of faults. The study of IEEE was carried out on various motors in industrial applications. As per the IEEE Standard 493-1997 the most common faults and their statistical occurrences are shown in Table 2.2. Under EPRI sponsorship, a study was conducted by General Electric Company on the basis of the report of the motor manufacturer. As per their report the main motor faults are presented in Table 2.3 [7, 9].

Faults in induction motors can be categorized as follows:

- (a) **Electrical-related faults:** Faults under this classification are unbalance supply voltage or current, single phasing, under or over voltage of current, reverse phase sequence, earth fault, overload, inter-turn short-circuit fault, and crawling.
- (b) **Mechanical-related faults:** Faults under this classification are broken rotor bar, mass unbalance, air gap eccentricity, bearing damage, rotor winding failure, and stator winding failure.
- (c) **Environmental-related faults:** Ambient temperature as well as external moisture will affect the performance of induction motor. Vibrations of machine, due to any reason such as installation defect, foundation defect, etc., also will affect the performance.

Table 2.3 Fault occurrence possibility on induction motor [7, 9]

| Studied by | Bearing fault (%) | Stator fault (%) | Rotor fault (%) | Others (%) |
|------------|-------------------|------------------|-----------------|------------|
| IEEE | 42 | 28 | 8 | 22 |
| EPRI | 41 | 36 | 9 | 14 |

Faults shown in Table 2.3 are in broad sense; stator fault may be of different kinds, and different types of faults may occur in rotor itself. For identification, faults in induction motors may be listed as follows—(i) broken bar fault, (ii) rotor mass unbalance fault, (iii) bowed rotor fault, (iv) bearing fault, (v) stator winding fault, (vi) single phasing fault, etc. Besides, the phenomenon called crawling when motor does not accelerate up to its rated speed but runs at nearly one-seventh of its synchronous speed is also considered as a fault of an induction motor. Faults listed (i)–(iii) are in general stated as rotor fault which contributes about 8–9 % of the total motor fault. In this work, broken bar fault, rotor mass unbalance fault, stator winding fault, single phasing fault, and crawling are considered.

In an induction motor multiple faults may occur simultaneously and in that case determination of the initial problem is quite difficult [10]. Effects of such faults in induction motor result in unbalanced stator currents and voltages, oscillations in torque, reduction in efficiency and torque, overheating, and excessive vibration [11]. Moreover, these motor faults can increase the magnitude of certain harmonic components of currents and voltages. Induction motor performance may be affected by any of the faults. In the next few paragraphs, causes and effects of different faults in induction motors are discussed.

2.5 Broken Rotor Bar Fault

2.5.1 General Description of Broken Rotor Bar

The squirrel cage of an induction motor consists of rotor bars and end rings. If one or more of the bars is partially cracked or completely broken, then the motor is said to have broken bar fault. Figure 2.6 shows rotor and parts of broken rotor bar.

2.5.2 Causes of Broken Rotor Bar

There are a number of reasons for which rotor faults may occur in an induction motor [12]. It has been observed that in squirrel-cage induction motor rotor asymmetry occurs mainly due to manufacturing defect, such as during the brazing process nonuniform metallurgical stresses may occur in cage assembly which led to failure during rotation of the rotor. Also heavy end rings of rotor result in large centrifugal forces which may cause extra stresses on the rotor bars. Because of any

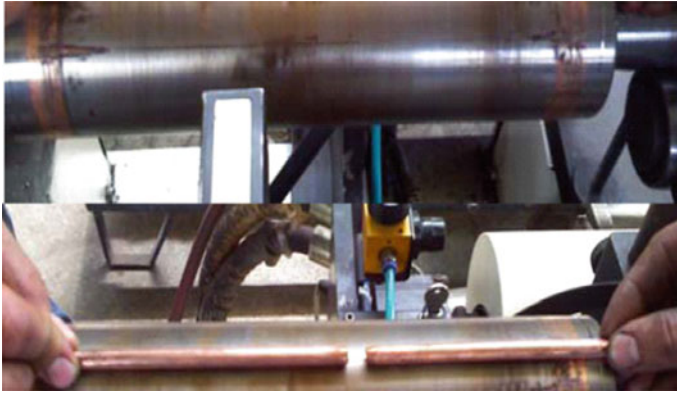

Fig. 2.6 Photograph of rotor and parts of broken rotor bar [16]

of the reasons rotor bar may get damage which results in asymmetrical distribution of rotor currents. Also, for such asymmetry or for long run of the motor if any of the rotor bar gets cracked overheating will occur in the cracked position which may lead to breaking of the bar. Now if one of the bars breaks, the side bars will carry higher currents for which larger thermal and mechanical stresses may happen on these side bars. If the rotor continues to rotate in this condition, the side bars may also get cracked [13]—thus damage may spread, leading to fracture of multiple bars of the rotor. This cracking may occur at various locations of the rotor, such as in bars, in end rings, or at the joints of bars and end rings. Possibility is more at the joints of bars and end rings. Moreover, possibilities of crack increase if motor start-up time is long and also if motor is subject to frequent starts and stops [14].

The main causes of rotor broken bar of an induction motor can be mentioned, pointwise, as follows:

- manufacturing defects
- thermal stresses
- mechanical stress caused by bearing faults
- frequent starts of the motor at rated voltage
- due to fatigue of metal of the rotor bar.

2.5.3 Effect of Broken Rotor Bar

Cracked or broken bar fault produces a series of sideband frequencies [15, 16], in the stator current signature given by

$$f_{\text{brb}} = f(1 \pm 2ks) \quad (2.1)$$

where f is the supply frequency, s is the slip, and k is an integer.

This has been demonstrated as ripple effect in [16], which explains that the lower side band at $f(1-2s)$ is the strongest which will cause ripples of torque and speed at a frequency of $2sf$ and this in turn will induce an upper side band at $f(1 + 2s)$ and this effect will continue to create the above series of sidebands, i.e., $f(1 \pm 2ks)$. Magnitude of this lower sideband $f(1 - 2s)$ over the fundamental can be used as an indicator of rotor broken bar fault [17].

2.6 Rotor Mass Unbalance

From the knowledge of construction of motor it is known that rotor is placed inside the stator bore and it rotates coaxially with the stator. In a healthy motor, rotor is centrally aligned with the stator and the axis of rotation of the rotor is the same as the geometrical axis of the stator. This results in identical air gap between the outer surface of the rotor and the inner surface of the stator. However, if the rotor is not centrally aligned or its axis of rotation is not the same as the geometrical axis of the stator, then the air gap will not be identical and the situation is referred as air-gap eccentricity. In fact air-gap eccentricity is common to rotor fault in an induction motor. Air-gap eccentricity may occur due to any of the rotor faults like rotor mass unbalance fault, bowed rotor fault, etc. Due to this air-gap eccentricity fault, in an induction motor electromagnetic pull will be unbalanced. The rotor side where the air gap is minimum will experience greater pull and the opposite side will experience lower pull and as a result rotor will tend to move in the greater pull direction across that gap [18]. The chance of rotor pullover is normally greatest during the starting period when motor current is also the greatest. In severe case rotor may rub the stator which may result in damage to the rotor and/or stator [19]. Air-gap eccentricity can also cause noise and/or vibration.

2.6.1 *General Description of Rotor Mass Unbalance*

This rotor mass unbalance occur mainly due to manufacturing defect, if not may occur even after an extended period of operation, for nonsymmetrical addition or subtraction of mass around the center of rotation of rotor or due to internal misalignment or shaft bending due to which the center of gravity of the rotor does not coincide with the center of rotation. In severe case of rotor eccentricity, due to unbalanced electromagnetic pull if rotor rubs the stator then a small part of material of rotor body may wear out which is being described here as subtraction of mass, resulting in rotor mass unbalance fault. Figure 2.7 shows rotor mass unbalance fault.

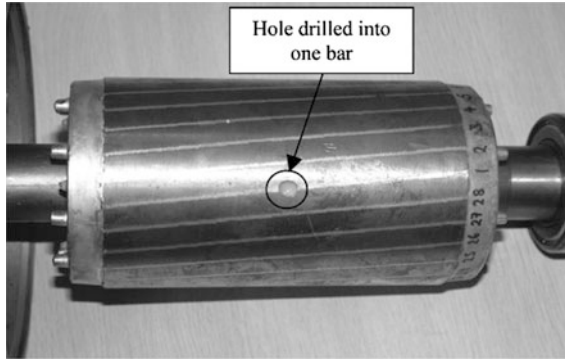

Fig. 2.7 Rotor with mass unbalance fault

2.6.2 Classification of Mass Unbalance

There are three types of mass unbalanced rotor:

- (a) Static mass unbalanced rotor
- (b) Couple unbalance rotor
- (c) Dynamic unbalance rotor.

2.6.2.1 Static Mass Unbalanced Rotor

For this fault shaft rotational axis and weight distribution axis of rotor are parallel but offset, as shown in Fig. 2.8. Without special equipment this type of eccentricity is difficult to detect [20].

2.6.2.2 Couple Unbalance Rotor

It is shown in Fig. 2.9. If this fault occurs then the shaft rotational axis and weight distribution axis of rotor intersect at the center of the rotor.

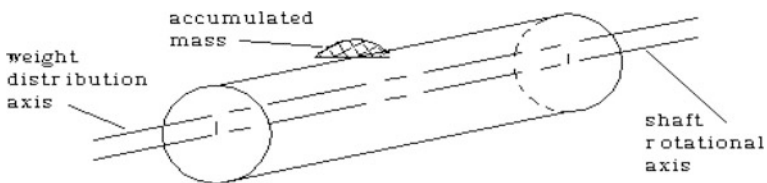

Fig. 2.8 Static mass unbalanced rotor

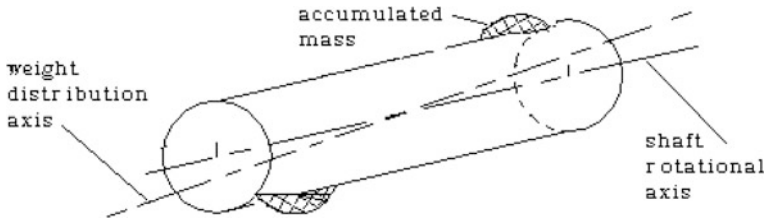

Fig. 2.9 Couple unbalanced rotor

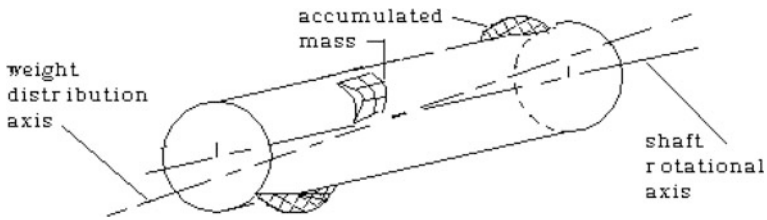

Fig. 2.10 Dynamic unbalanced rotor

2.6.2.3 Dynamic Unbalance Rotor

It is shown in Fig. 2.10. If this fault occurs then shaft rotational axis and weight distribution axis of rotor do not coincide. It is the combination of coupling unbalance and static unbalance.

The main causes of rotor mass unbalance in an induction motor can be mentioned, pointwise, as follows:

- manufacturing defect
- internal misalignment or shaft bending
- it may occur after an extended period of operation, for nonsymmetrical addition or subtraction of mass around the center of rotation of rotor.

2.6.3 Effect of Rotor Mass Unbalance

If in an induction motor rotor mass unbalance occurs, its effect will be as follows:

- Mass unbalance produces dynamic eccentricity which results in oscillation in the air gap length.
- Oscillation in the air gap length causes variation in air gap flux density, and hence variation in induced voltage in the winding.

- Induced voltage causes current whose frequencies are determined by the frequency of the air gap flux density harmonics. The stator current harmonics [21, 22] is given by

$$f_{ubm} = f \left[\frac{k(1-s)}{p} \right] + 1 \quad (2.2)$$

where f is the supply frequency, s is the slip of the motor, p is the number of pole pair, and k is an integer.

2.7 Bearing Fault

Two sets of bearings are placed at both the ends of the rotor of an induction motor to support the rotating shaft. They held the rotor in place and help it to rotate freely by decreasing the frictions. Each bearing consists of an inner and an outer ring called races and a set of rolling elements called balls in between these two races. Normally, in case of motor, inner race is attached to the shaft and load is transmitted through the rotating balls—this decreases the friction. Using lubricant (oil or grease) in between the races friction is further decreased. Figure 2.11 shows a typical ball bearing and Fig. 2.12 shows a dissected ball bearing.

Any physical damage of the inner race or in the outer race or on the surface of the balls is termed as bearing fault. In terms of induction motor failure, bearing is the weakest component of an induction motor. It is the single largest cause of fault in induction motor. As per the study of IEEE and EPRI, given in Table 2.3, 41–42 % of induction motor faults are due to bearing failure [7, 9].



Fig. 2.11 Ball bearing

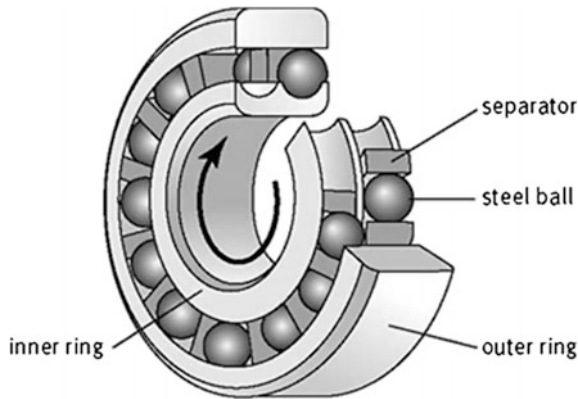

Fig. 2.12 Ball bearing (dissected)

Causes and effects of bearing failure:

1. Excessive loads, tight fits, and excessive temperature rise: all of these can anneal the two races and ball materials. They can also degrade, even destroy, the lubricant. If the load exceeds the elastic limit of the bearing material, brinelling occurs.
2. Fatigue failure: this is due to long run of the bearings. It causes fracture and subsequently removal of small discrete particles of materials from the surfaces of races or balls. This type of bearing failure is progressive, that is, if once initiated will spread when further operation of bearings takes place. For this bearing failure, vibration and noise level of motor will increase [23].
3. Corrosion: this results if bearings are exposed to corrosive fluids (acids, etc.) or corrosive atmosphere. If lubricants deteriorate or the bearings are handled carelessly during installation, then also corrosion of bearings may take place [23]. Early fatigue failure may creep in due to corrosion.
4. Contamination: it is one of the leading factors of bearing failure. Lubricants get contaminated by dirt and other foreign particles which are most often present in industrial environment. High vibration and wear are the effects of contamination.
5. Lubricant failure: for restricted flow of lubricant or excessive temperature this takes place. It degrades the property of the lubricant for which excessive wear of balls and races takes place which results in overheating. If bearing temperature gets too high, grease (the lubricant) melts and runs out of bearing. Discolored balls and ball tracks are the symptoms of lubricant failure.
6. Misalignment of bearings: for this, wear in the surfaces of balls and races takes place which results in rise in temperature of the bearings.

It is observed that for any of the bearing failures, normally friction increases which causes rise in temperature of the bearings and increase in vibration of the concerned machine. For this, bearing temperature and vibration can provide useful information regarding bearing condition and hence machine health [23, 24].

2.8 Stator Fault

Stator of an induction motor is subjected [25] to various stresses such as mechanical, electrical, thermal, and environmental [18]. Depending upon the severity of these stresses stator faults may occur. If for a well-designed motor operations and maintenance are done properly, then these stresses remain under control. The stator faults can be classified as (i) faults in laminations and frame of stator and (ii) faults in stator winding. Out of these the second one is the most common stator fault. As per the study of IEEE and EPRI, given in Table 2.3, 28–36 % of induction motor faults are stator winding fault [7, 9]. Majority of these faults are due to a combination of above stresses.

2.8.1 Stator Winding Fault

This fault is due to failure of insulation of the stator winding. It is mainly termed as inter-turn short-circuit fault. Different types of stator winding faults are (i) short circuit between two turns of same phase—called turn-to-turn fault, (ii) short circuit between two coils of same phase—called coil to coil fault, (iii) short circuit between turns of two phases—called phase to phase fault, (iv) short circuit between turns of all three phases, (v) short circuit between winding conductors and the stator core—called coil to ground fault, and (vi) open-circuit fault when winding gets break. Different types of stator winding faults are shown in Fig. 2.13. Short-circuit winding fault shows up when total or a partial of the stator windings get shorted. Open-circuit fault shows up when total or a partial of the stator windings get disconnected and no current flows in that phase/line (Figs. 2.14 and 2.15).

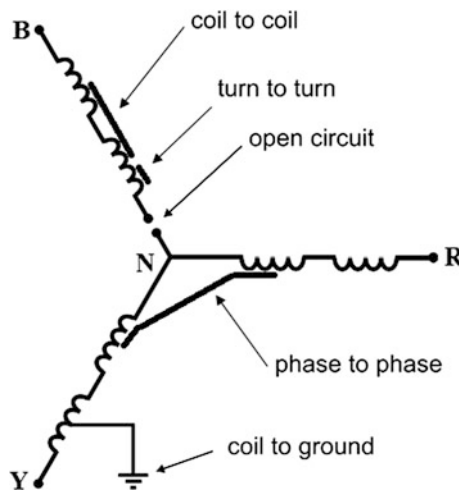

Fig. 2.13 Star-connected stator showing different types of stator winding fault

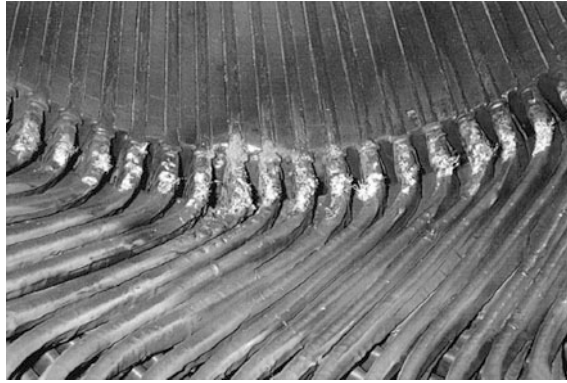

Fig. 2.14 Photograph of damage stator winding

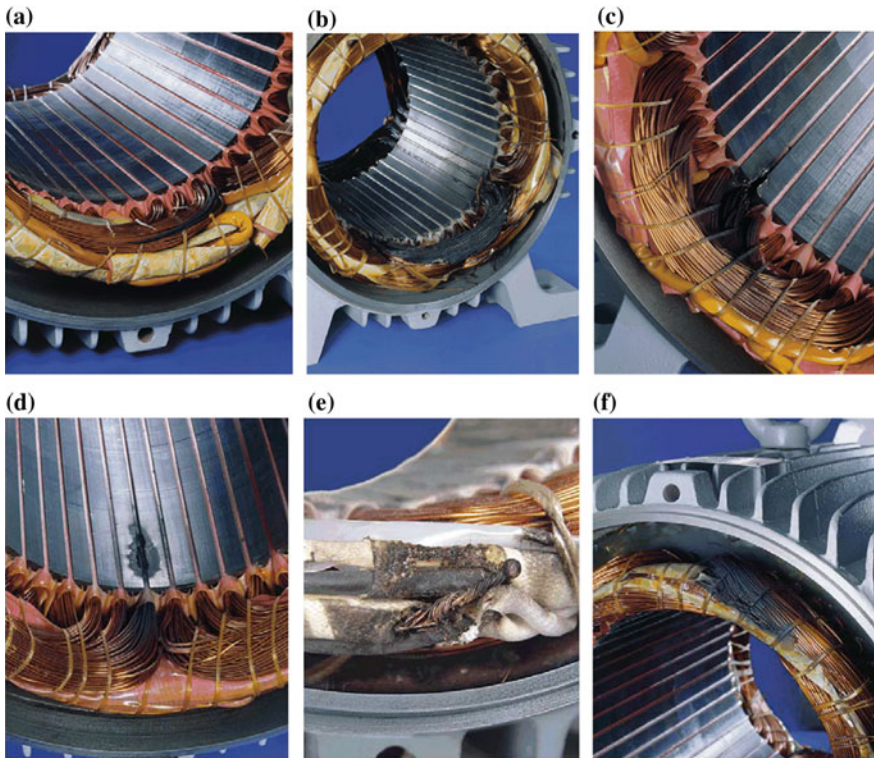

Fig. 2.15 Typical insulation damage leading to inter-turn short circuit of the stator windings in three-phase induction motors. **a** Inter-turn short circuits between turns of the same phase. **b** Winding short circuited. **c** Short circuits between winding and stator core at the end of the stator slot. **d** Short circuits between winding and stator core in the middle of the stator slot. **e** Short circuit at the leads. **f** Short circuit between phases

2.8.2 Causes and Effects of Stator Winding Faults

- (i) **Mechanical Stresses**—these are due to movement of stator coil and rotor striking the stator [25]. Coil movement which is due to the stator current (as force is proportional to the square of the current [26]) may loosen the top sticks and also may cause damage to the copper conductor and its insulation. Rotor may strike the stator due to rotor-to-stator misalignment or due to shaft deflection or due to bearing failure and if strikes then the striking force will cause the stator laminations to puncture the coil insulation resulting coil to ground fault. High mechanical vibration may disconnect the stator winding producing the open-circuit fault [27].
- (ii) **Electrical Stresses**—these are mainly due to the supply voltage transient. This transient arises due to different faults (like line-to-line, line-to-ground, or three-phase fault), due to lightning, opening, or closing of circuit breakers or due to variable frequency drives [25]. This transient voltage reduces life of stator winding and in severe case may cause turn-to-turn or turn-to-ground fault.
- (iii) **Thermal stresses**—these are mainly due to thermal overloading and are the main reason, among the other possible causes, for deterioration of the insulation of the stator winding. Thermal stress happens due to over current flowing due to sustained overload or fault, higher ambient temperature, obstructed ventilation, unbalanced supply voltage, etc. [25]. A thumb rule is there which states that winding temperature will increase by 25 % in the phase having the highest current if there is a voltage unbalance of 3.5 % per phase [18]. Winding temperature will also increase if within a short span of time a number of starts and stops are made in the motor. What may be the reason, if winding temperature increases and the motor is operated over its temperature limit, the best insulation may also fail quickly. The thumb rule, in this regard, states that for every 10 °C increase in temperature above the stator winding temperature limit, the insulation life is reduced by 50 % [28, 18]. Table 2.4 shows the effect of rise of temperature above ambient on the insulation of winding [18].
- (iv) **Environmental stresses**—these stresses may arise if the motor operates in a hostile environment with too hot or too cold or too humid. The presence of foreign material can contaminate insulation of stator winding and also may reduce the rate of heat dissipation from the motor [29], resulting reduction in

Table 2.4 Effect of rise of temperature

| Ambient in °C | Insulation life in hours |
|---------------|--------------------------|
| 30 | 250,000 |
| 40 | 125,000 |
| 50 | 60,000 |
| 60 | 30,000 |

insulation life. Air flow should be free where the motor is situated, otherwise the heat generated in the rotor and stator will increase the winding temperature which will reduce the life of insulation.

2.9 Single Phasing Fault

This is a power supply-related electrical fault in case of an induction motor. For a three-phase motor when one of the phases gets lost then the condition is known as single phasing.

2.9.1 Causes of Single Phasing Fault

Single phasing fault in an induction motor may be due to

- A downed line or a blown fuse of the utility system.
- Due to an equipment failure of the supply system.
- Due to short circuit in one phase of the star-connected or delta-connected motor.

2.9.2 Effects of Single Phasing Fault

Effects of single phasing fault are as follows:

- For single phasing fault motor windings get over heated, primarily due to flow of negative sequence current.
- If during running condition of the motor single phasing fault occurs motor continues to run due to the torque produced by the remaining two phases and this torque is produced as per the demand by the load—as a result healthy phases may be over loaded and hence over heated resulting in critical damage to the motor itself.
- A three-phase motor will not start if a single phasing fault already persists in the supply line.

2.10 Crawling

It is an electromechanical fault of an induction motor. When an induction motor, though the full-load supply is provided, does not accelerate but runs at a speed nearly one-seventh of its synchronous speed, the phenomenon is known as crawling of the motor.

2.10.1 General Description

The air-gap flux in between stator and rotor of an induction motor is not purely sinusoidal because it contains some odd harmonics. Due to these harmonics, unwanted torque is developed. The flux due to third harmonics and its multiples produced by each of the three phases differs in time phase by 120° and hence neutralize each other. For this reason, harmonics present in air-gap flux are normally 5th, 7th, 11th, etc.

The fundamental air-gap flux rotates at synchronous speed given by $N_s = 120f/P$ rpm where f is the supply frequency and P is the number of poles. However, harmonic fluxes rotate at N_s/k rpm speed (k denotes the order of the harmonics), in the same direction of the fundamental except the 5th harmonic. Flux due to 5th harmonic rotates in opposite direction to the fundamental flux. Magnitudes of 11th and higher order harmonics being very small 5th and 7th harmonics are the most important and predominant harmonics.

Like fundamental flux these two harmonic fluxes also produce torque. Thus total motor torque has three components—(i) fundamental torque rotating at synchronous speed N_s (ii) 5th harmonic torque rotating at speed $N_s/5$ in the opposite direction of fundamental, and (iii) 7th harmonic torque rotating at speed $N_s/7$ in the same direction of fundamental. Thus 5th harmonic torque produces a braking action whose magnitude is very small and hence can be neglected; consequently, the resultant torque can be taken as the sum of the fundamental torque and the 7th harmonic torque as shown in Fig. 2.16. The 7th harmonic torque has value zero at one-seventh of the synchronous speed. The resultant torque shows a dip near slip $6/7$, which is more significant because torque here decreases with increase in speed. The motor under loaded condition will not accelerate up to its normal speed but will remain running at a speed nearly one-seventh of the synchronous speed. This phenomenon is called crawling of the induction motor. It is predominant in the squirrel-cage type induction motor. By proper selection of the number of stator and rotor slots, the crawling effect can be reduced.

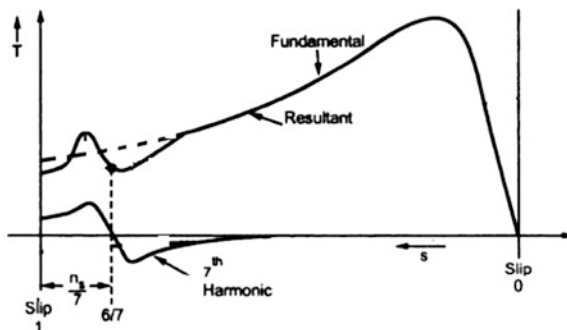

Fig. 2.16 Torque-slip curve showing resultant of fundamental and 7th harmonic torque

2.10.2 Causes of Crawling

Crawling is caused by the 7th harmonic. The 7th harmonic is introduced due to abnormal magneto motive force. Another reason is high harmonic content in the power supply to the motor.

2.10.3 Effects of Crawling

Following are the effects of crawling:

- Motor under loaded condition will not accelerate up to its normal speed.
- Loaded motor will remain running at a speed nearly one-seventh of the synchronous speed.
- There will be much higher stator current.
- Motor vibration and noise will be high.

2.11 Over Voltage, Under Voltage, Overload, and Blocked Rotor

Over and under voltages occur due to change of voltage level at supply end. Over voltage causes stress on insulation, whereas under voltage causes excessive line current increasing temperature of the winding. These faults are normally detected by over/under voltage relays. Overload occurs due to increase of mechanical load above the rating of the motor. At excessive mechanical load, rotor fails to rotate and gets blocked. This situation is equivalent to short circuit. Normally, overload and blocked rotor are protected by over current relay or simply fuse.

2.12 Condition Monitoring and Its Necessity

Induction motors are the main workhorse of industrial prime movers due to their ruggedness, low cost, low maintenance, reasonably small size, reasonably high efficiency, and operating with an easily available power supply. About 50 % of the total generated power of a nation is consumed by these induction motors [30]. This statistics gives an idea regarding the use of huge number of induction motors, but they have some limitations in their operating conditions. If these conditions exceed then some premature failure may occur in stator or/and rotor. This failure, in many applications in industry, may shut down, even, the entire industrial process resulting loss of production time and money. Hence, it is an important issue to avoid any kind of failure of induction motor. Operators and technicians of induction motors

are under continual pressure to prevent unscheduled downtime and also to reduce maintenance cost of motors.

Maintenance of electrical motors can be done in three forms: breakdown maintenance, fixed-time maintenance, and condition-based maintenance. In breakdown maintenance, the strategy is ‘run the motor until it fails’ which means maintenance action is taken only when the motor gets break down. In this case though the motor may run comparatively for a long time before the maintenance is done but when break down occurs it is necessary to replace the entire machine which is much costlier compared to replacing or repairing the faulty parts of the motor. Also it causes loss of productivity due to downtime. In fixed-time maintenance, motor is required to stop for inspection which causes long downtime. Also trained and experienced technical persons are required to recognize each and every fault correctly. All these necessitate the condition-based maintenance of the motor. In this form of maintenance, motor is allowed to run normally and action is taken at the very first sign of an incipient fault. There are a number of works [31–37] on this online condition monitoring of induction motor.

In condition monitoring, when a fault has been identified, sufficient data is required for the plant operator for the best possible decision making on the correct course of action. If data is insufficient there remains the chance for wrong diagnosis of fault which leads to inappropriate replacement of components, and if the root of the problem is not identified properly, the replacement or any other action taken already will succumb to the same fate.

In condition monitoring, signals from the concerned motor are continuously fed to the data acquisition system and the health of the motor is continuously evaluated during its operation for which it is also referred as online condition monitoring of motor, and hence it is possible to identify the faults even while they are developing. The operator/technician can take preparation for the preventive maintenance and can arrange for necessary spare parts, in advance, for repairing. Thus condition monitoring can optimize maintenance schedule and minimize motors downtime [9] and thereby increase the reliability of the motor. Advantages of using condition monitoring can be mentioned pointwise as below:

- Can predict the motor failure.
- Can optimize the maintenance of the motor.
- Can reduce the maintenance cost.
- Can reduce downtime of the machine.
- Can improve the reliability of the motor.

References

1. Krause PC (1986) Analysis of electric machinery. Mc-Graw Hill, New York
2. Sen PC (1989) Principles of electric machines and power electronics. Willey, New York
3. Say MG (2002) The performance and design of alternating current machines. M/S Pitman, London. ISBN 81-239-1027-4

4. Kothari DP, Nagrath IJ (2010) Electric machines. Tata McGraw Hill Education Pvt. Ltd., New Delhi. ISBN-13 978-0-07-069967-0
5. Motor Reliability Working Group (1985) Report of large motor reliability survey of industrial and commercial installations Part I, and II. IEEE Trans Ind Appl IA-21(4):853–872
6. Thorsen OV, Dalva M (1995) A survey of faults on induction motors in offshore oil industry, petrochemical industry, gas terminals, and oil refineries. IEEE Trans Ind Appl 31(5):1186–1196
7. Singh GK, Al Kazzaz SAS (2003) Induction machine drive condition monitoring and diagnostic research—a survey. Electr Power Syst Res 64(2):145–158
8. IEEE recommended practice for the design of reliable industrial and commercial power systems. IEEE Standard 493–1997 [IEEE Gold Book]
9. Allbrecht PF, Appiarius JC, McCoy RM, Owen EL (1986) Assessment of the reliability of motors in utility applications—updated. IEEE Trans Energy Convers EC-1(1):39–46
10. Bonnett AH, Soukup GC (1988) Analysis of rotor failures in squirrel-cage induction motors. IEEE Trans Ind Appl 24:1124–1130
11. Su H, Chong KT, Kumar RR (2011) Vibration signal analysis for electrical fault detection of induction machine using neural networks. Neural Comput Appl 20(2):183–194, Springer
12. Vas P (1993) Parameter estimation, condition monitoring and diagnosis of electrical machines. Clarendon Press, Oxford
13. Tavner PJ, Penman J (1987) Condition monitoring of electrical machines. Research Studies Press Ltd., Hertfordshire, England. ISBN 0863800610
14. Bonnet AH, Soukup GC (1992) Cause and analysis of stator and rotor failures in three phase squirrel cage induction motors. IEEE Trans Ind Appl 28(4):921–937
15. Deleroi W (1984) Broken bars in squirrel cage rotor of an induction motor—part I: description by superimposed fault currents. Arch Elektrotech 67:91–99
16. Filippetti F, Franceschini G, Tassoni C, Vas P (1998) AI techniques in induction machines diagnosis including the speed ripple effect. IEEE Trans Ind Appl 34:98–108
17. Bellini A, Concarì C, Franceschini G, Lorenzani E, Tassoni C, Toscani A (2006) Thorough understanding and experimental validation of current sideband components in induction machines rotor monitoring. In: IECON 2006-32nd annual conference on IEEE industrial electronics, pp 4957–4962
18. Bonnett Austin H, Soukup GC (1992) Cause and analysis of stator and rotor failures in three phase squirrel-cage induction motors. IEEE Trans Ind Appl 28(4):921–937
19. Dorrell DG, Thomson WT, Roach S (1997) Analysis of air-gap flux, current and vibration signals as function of a combination of static and dynamic eccentricity in 3-phase induction motors. IEEE Trans Ind Appl 33:24–34
20. Bradford M (1968) Unbalanced magnetic pull in a 6-pole induction motor. IEEE Proc Electr Eng 115(11):1619–1627
21. M'hamed D, Cardoso AJM (2008) Air gap eccentricity fault diagnosis in three phase induction motor by the complex apparent power signature analysis. IEEE Trans Ind Electr 55(3):1404
22. Hwang DH, Lee KC, Lee JH, Kang DS, Lee JH, Choi KH, Kang S et al (2005) Analysis of a three phase induction motor under eccentricity condition. In: 31st annual conference of IEEE industrial electronics society, IECON2005, pp 6–10
23. Eschmann P, Hasbargen L, Weigand K (1958) Ball and roller bearings: their theory, design and application. K. G. Heyden, London
24. Schoen RR, Habetler TG, Kamran F, Bartheld RG (1995) Motor bearing damage detection using stator current monitoring. IEEE Trans Ind Appl 31(6):1274–1279
25. Siddique A, Yadava GS, Singh B (2005) A review of stator fault monitoring techniques of induction motors. IEEE Trans Energy Convers 20(1):106–114
26. Lee SB, Tallam RM, Habetler TG (2003) A robust on-line turn-fault detection technique for induction machines based on monitoring the sequence component impedance matrix. IEEE Trans Power Electr 18(3):865–872

27. Aguayo J, Claudio A, Vela LG, Lesecq S, Barraud A (2003) Stator winding fault detection for an induction motor drive using actuator as sensor principle. IEEE xplore 0-7803-7754-0/03@2003 IEEE
28. Lipo TA (2004) Introduction of AC machine design, 2nd edn. Wisconsin Power Electronics Research Center, Madison
29. Cash MA (1998) "Detection of turn faults arising from insulation failure in the stator windings of AC machines", Doctoral Dissertation. Department of Electrical and Computer Engineering, Georgia Institute of Technology, USA
30. Thomson WT, Gilmore RJ (2003) Motor current signature analysis to detect faults in induction motor drives-fundamentals, data interpretation, and industrial case histories. In: Proceedings of the thirty-second turbomachinery symposium, pp 145–156
31. Jung JH, Lee JJ, Kwon BH (2006) Online diagnosis of induction motors using MCSA. IEEE Trans Ind Electron 53(6):1842–1852
32. Tavner PJ (2008) Review of condition monitoring of rotating electrical machines. IET Electr Power Appl 2(4), 215
33. Nandi S, Toliyat HA (1999) Condition monitoring and fault diagnosis of electrical machines—a review. In: Proceedings 34th annual meeting of IEEE industrial applications society, pp 197–204
34. Ahmed I, Supangat R, Grieger J, Ertugrul N, Soong WL (2004) A baseline study for online condition monitoring of induction machines. In: Australian Universities power engineering conference (AUPEC), Brisbane, Australia
35. Thomson WT, Rankin D, Dorrell DG (1999) On-line current monitoring to diagnose air gap eccentricity in large three-phase induction motors—industrial case histories to verify the predictions. IEEE Trans Energy Convers 14(4):1372–1378
36. Thomson WT, Barbour A (1998) On-line current monitoring and application of a Finite Element method to predict the level of air gap eccentricity in 3-Phase induction motor. IEEE Trans Energy Convers 13(4):347–357
37. Wolbank TM, Macheiner PE (2007) Adjustment, measurement and on-line detection of air gap asymmetry in AC machines. IEEE, Vienna, Austria
38. Benbouzid MEH (2000) A review of Induction motor Signature analysis as a medium for Fault detection. IEEE Trans Ind Electron 47(5):984–993
39. Gaeid KS, Mohamed HAF (2010) Diagnosis and fault tolerant control of the induction motors techniques a review. Aust J Basic Appl Sci 4(2):227–246. ISSN 1991-8178